

# A design study of a CMB polarization satellite SAMPAN and Bolometric Camera Developments<sup>★</sup>

F.–X. Désert

*LAOG, Observatoire de Grenoble  
BP 53, 414 rue de la piscine, 38041 Grenoble Cedex 9, France*<sup>1</sup>

---

## Abstract

There is a strong theoretical case for measuring the primordial gravitational wave background that is expected in inflation–based Big Bang scenario. A promising route is via the polarization B–modes of the CMB anisotropies. We discuss a recent design study called SAMPAN for a moderate angular resolution (20 arcmin. at 217 GHz) but highly sensitive ( $5\ \mu\text{K}\cdot\text{arcmin}$ ) polarization mapper satellite. In parallel, we describe recent efforts in France to build bolometric cameras.

*Key words:* Cosmic Microwave Background, Polarization, Bolometric detectors, Cosmology

---

## 1 A design study for a B–mode satellite

After the ground–breaking results from the first generation satellite COBE (Smoot et al. , 1992) and from the more recent second generation satellite WMAP (Bennett et al. , 2003), the ESA PLANCK mission should provide an even more precise characterization of the CMB primary anisotropies in 2008 (The Planck Collaboration , 2006). This satellite should also make cosmic variance limited measurements of the E–mode polarization of the CMB. These E–modes, produced primarily by scalar perturbations at recombination, are closely linked to the temperature anisotropies and will provide stringent

---

<sup>★</sup> This article summarizes work done by many contributors, including B. Belier, A. Benoit (DCMB leader), F. R. Bouchet (SAMPAN leader), M. Bucher, Ph. Camus, Ph. Desmet, L. Dumoulin, Y. Jin, J. Michaud (CNES study leader), M. Piat, N. Ponthieu, D. Santos, S. Triqueneaux, S. Yates

<sup>1</sup> email: Francois-Xavier.Desert@obs.ujf-grenoble.fr

consistency checks and break degeneracies among some of the cosmological parameters.

On the other hand, primordial B-modes can only be produced by tensor perturbations, most notably gravitational waves (Kamionkowski et al. , 1997; Seljak and Zeldarriaga , 1997). They have been shown to provide unique information about the inflationary phase of the Universe (Bond & Efstathiou , 1984), most notably the energy scale of inflation. Although PLANCK can already set valuable limits on the tensor-to-scalar power spectrum ratio  $r = \frac{T}{S}$  at the level of  $10^{-1}$ , we have here designed a satellite dedicated to CMB polarization measurements with the aim of reaching limits of  $r \sim 10^{-3}$ , which is a natural target for GUT motivated inflation models. This phase 0 design study in 2005, named SAMPAN (Bouchet et al. , 2005) was commissioned by CNES (the French space agency) in order to study its feasibility, cost and critical technologies, with significant industrial contributions by Alcatel Alenia Space and Air Liquide.

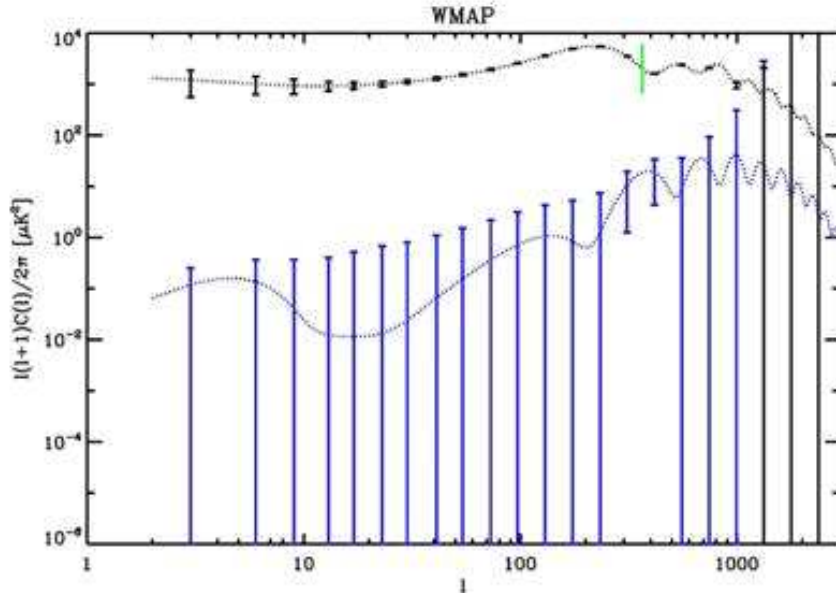

Fig. 1. Wmap one year sensitivity to TT and EE power spectra

In order to obtain that goal which translates into measuring the polarization of the CMB at the nanoKelvin level on large scales, we devise the following requirements: 1) a full sky survey, which can only be done from space, 2) a strict control of foreground polarized emissions hence at least 4 frequency bands, typically 100, 143, 217 to 353 GHz, 3) an angular resolution of 20 arcmin at 217 GHz, 4) sensitivity (see below) 5) a strict control of systematic effects.

Bolometer arrays are chosen because they offer the highest sensitivity at mil-

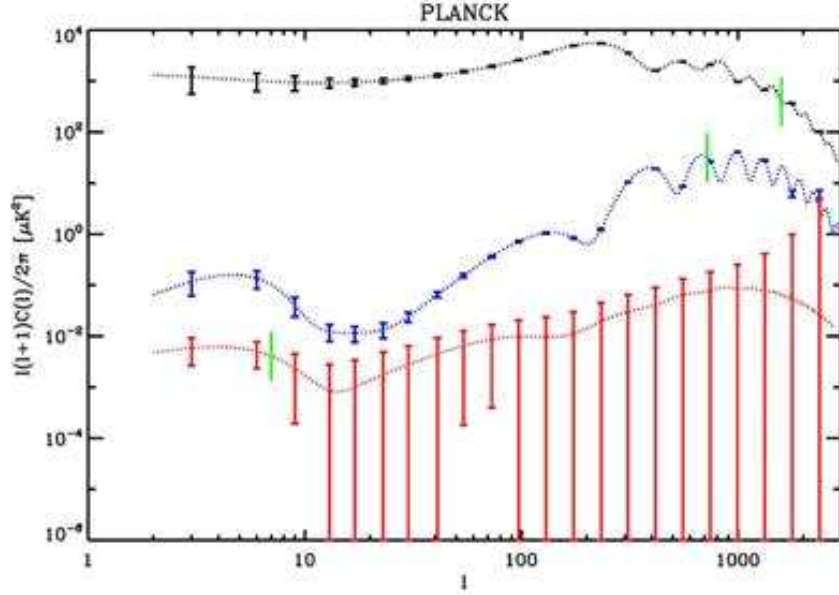

Fig. 2. Planck one year sensitivity to TT, EE, BB power spectra

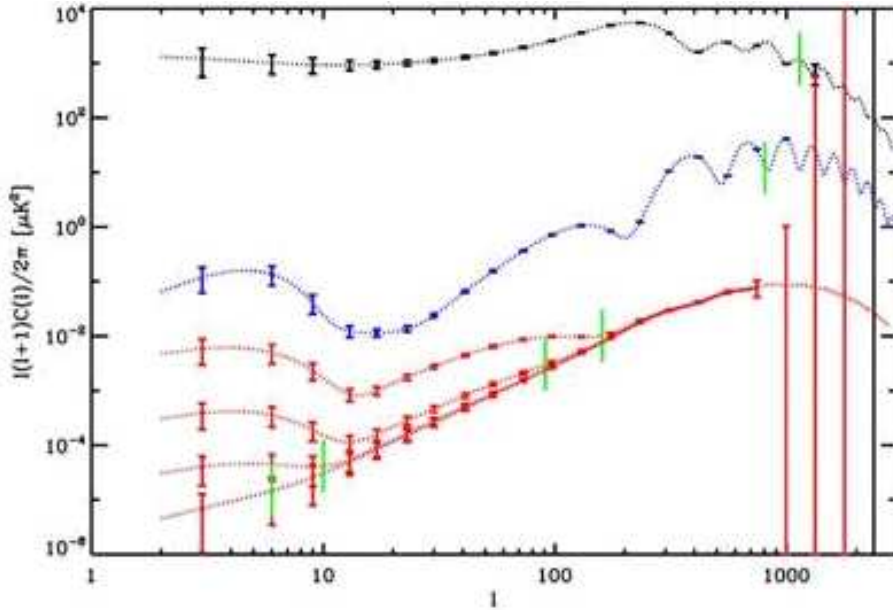

Fig. 3. Sampan sensitivity to TT, EE, BB power spectra. The four lower BB curves are respectively for  $r = 10^{-1}, 10^{-2}, 10^{-3}, 10^{-4}$  with a reionization opacity 0.11 compatible with the latest WMAP findings. The different figures are taken from (Bouchet , 2005).

limeter wavelengths, as exemplified by PLANCK HFI with respect to WMAP. PLANCK HFI bolometers are background noise limited, the background being close to the CMB itself. The only way to increase the raw instrumental sensitivity is by using large format arrays of bolometers. A natural target sensitivity of  $5 \mu\text{Karcmin}$  for the rms noise per square root of solid angle to match the

limit provided by the CMB foreground B-modes produced by weak lensing. Antenna-coupled bolometer arrays can provide the raw linear polarization sensitivity if about 20,000 detectors are gathered, with a Shannon sampling configuration (see Section 2).

The method of polarization measurement is to scan each detector, which is instantaneously sensitive to one linear polarization, across the sky with all possible orientation. By spinning the whole satellite, it becomes the polarizing analyzer itself. There is no moving part in the payload. A slow nutation and precession allows to access half of the available sky that can be observed from the Lagrangian L2 vantage point. The nutation and precession are possible at low thruster cost only if a counter-rotating momentum compensating wheel (available with  $\sim 1000$  N.m.s performance) brings the total satellite angular momentum to zero.

The basic control of systematics is provided by the measurement redundancy at several time scales, as shown in Fig. 4. The spin period is around 10 seconds. It insures that a given pair of polarized bolometers can measure the complete  $I, Q, U$  Stokes parameters ( $V$  being assumed to vanish) within few revolutions before the  $1/f$  noise starts to set in. Then the nutation and precession period of respectively 40 minutes and half a day provide the basket weaving method to tie the scans together and to measure correlation properties on angular scales of 40 degrees on a 10-minutes timescale. Half the sky is measured every other day. A complete sky coverage is obtained after 6 months and 4 surveys are completed after 2 years of mission. Obviously, instantaneous redundancy is provided across the detectors of a given array. A posteriori pointing solutions are deduced from fast star sensors that exist commercially.

The ability to view instantaneously half the sky, opposite to the Sun, Earth, and Moon group, means that the passive cooling which was done orthogonally to the spin axis for PLANCK, must be done along the spin axis for SAMPAN. We have shown that a proper shielding and a number of up to 3 V-grooves can produce a thermal stage at 50 K. This is an appropriate initial stage for further cool-down by a classic cryostat. This cryostat can work either with liquid Helium (2 K) or with solid hydrogen (8 K). Estimates of the total cryostat weight (including the cryogens) vary from 100 (solH solution) to 350 kg (liqHe solution).

The cryostat cools a refractive telescope made of two 30 cm diameter lenses that provides a very compact design with a cylindrical symmetry. To first order, very low polarized sidelobes should ensue from this design. The optical system is nearly telecentric and converges toward a nearly flat focal plane. It induces an instrument polarization of less than 1 % and has Strehl ratios above 99 %. Filtering and baffling are essential parts of the design.

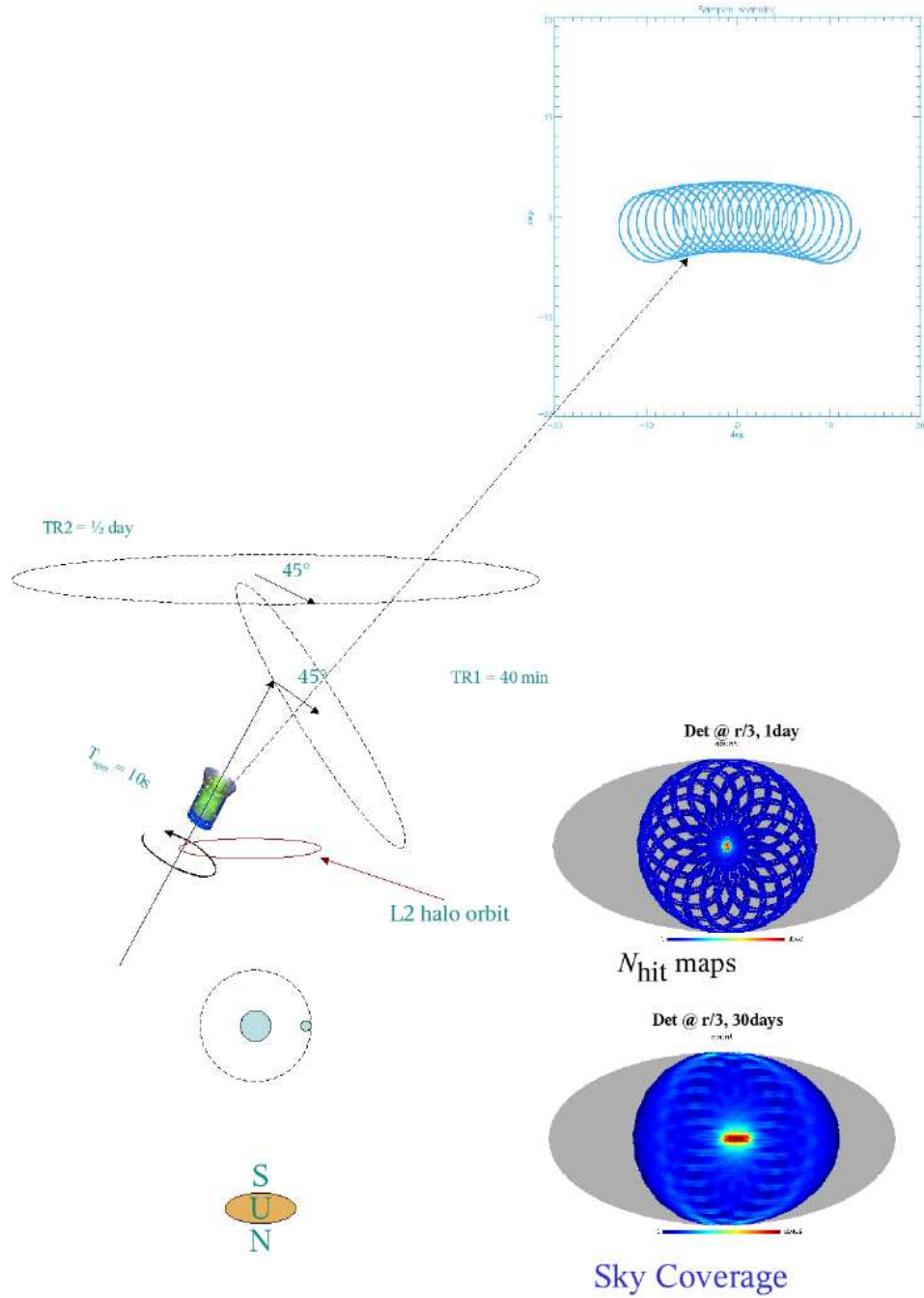

Fig. 4. Sampan schematic scan strategy. One detector imprint on the sky (upper right drawing) has its polarization state rotated at each of the scan crossings. Many time scales are built in order to control systematic effects. A single detector situated at a third of the total focal plane radius can cover half the sky in a few days (lower right plots).

The focal plane is cooled down to 100–200 mK by an open cycle  $^3\text{He}$ – $^4\text{He}$  dilution cooler very similar to the one used by PLANCK HFI. Because the focal plane has no concentrating optics (contrary to a more classical but too heavy

horn design), a careful baffling at an intermediate temperature (500 mK) prevents any unnecessary optical loading or stray light. The basic raw sensitivity of the mission is provided by arrays of bolometers, each being sensitive to one linear polarization. The number of detectors  $N_{det}$  per frequency channel can be deduced from the following argument.

The  $1\sigma$  instrumental noise on the power spectrum  $\Delta C_\ell$ , as shown in Fig. 3, can be deduced as:

$$\Delta C_\ell = \left( \frac{2}{(2\ell + 1)f_{sky}} \right)^{1/2} C_{noise} \exp \left[ \ell^2 \left( \frac{\theta}{2.35} \right)^2 \right],$$

where the beam FWHM is  $\theta$  in radians,  $f_{sky} \sim 1$  is the observed fraction of the sky and the instrument sensitivity is

$$C_{noise} = 2 \cdot 4\pi \cdot f_{sky} \cdot s_{det}^2 / N_{det} / T_{miss}.$$

In this expression, the factor 2 allows the conversion from temperature to  $Q$ ,  $U$  sensitivity,  $T_{miss}$  is the mission observing time and  $s_{det}$  is the individual detector Noise Equivalent Temperature sensitivity to an unpolarized source. Numerically one obtains:

$$C_{noise} = (5 \mu\text{K} \cdot \text{arcmin})^2 \left( \frac{2 \text{ years}}{T_{miss}} \right) \left( \frac{5000}{N_{det}} \right) \left( \frac{s_{det}}{140 \mu\text{K} \cdot \text{s}^{1/2}} \right)^2.$$

The typical detector sensitivity corresponds to space background limited performance, the CMB itself being the main background. In Shannon sampling focal plane array, about 5 detectors are needed to map one diffraction spot for one linear polarization. Therefore 5000 pixels provides a total field-of-view (FOV) equivalent to 500 diffraction spots. Electrical consumption and thermal dissipation due to the readout wiring have been evaluated and are compatible with satellite environment. The shear size of the focal plane, typically a diameter of 30 cm, identical to the lenses themselves, gives an idea of the daunting assembling task if bolometers were not integrated on chips.

One outcome of the study is to show the feasibility of a post-PLANCK mission, dedicated to large angular scale CMB polarization, within a weight cap of 2 tons. The unoptimized raw total costing  $\leq 480$  MEuros puts this mission outside the scope of national development. Implementation using the results of the SAMPAN study will be actively sought at the European level in the coming months within the ESA Cosmic Vision opportunities. Active design phases are also been pursued in the USA (Bock et al. , 2006).

## 2 Bolometric Camera Developments

The need to increase mapping speed on the next generation ground-based, suborbital and space instruments requires the use of the micro-machining lithographic techniques to mass produce pixel arrays with up to a thousand detectors per wafer. Because the design and realization of high-performance arrays rely on various areas of physics, several laboratories (APC, CRTBT, CSNSM, IAS, IEF, LAOG, LPSC, LPN, from CNRS) with different expertises in France are collaborating towards that global R & D goal. Initial options are now being consolidated which are:

- The use of planar antenna-coupled bolometers (Bock et al., 2002) allows us to decouple the size of the absorbing area, which has to be around the wavelength, from the size of the thermistor, which has to be the smallest possible. Other advantages over classical composite bolometers include a natural selection for polarization and some frequency bands, if some microstrip filtering is designed. In this respect, there is an actual convergence between the antenna design of bolometers and the radiometric techniques used by SIS or HEMT-based radiometers.
- Shannon sampling arrays have a high occupancy rate of the focal plane. They are favored here over the horn array design to benefit from collective effects and reduce weight at the lowest temperature (Désert & Benoit, 1999). It can be shown that a proper sampling of the diffraction Airy disc pattern at the longest absorbed wavelength ( $\lambda$ ) can be achieved if the effective size of each pixel, defined as the inverse square-root of the surface density of detectors, is  $n\lambda/2$  where  $n$  is the focal length to aperture ratio. Hence, for example, a fast optics ( $n \sim 2$ ) on a 1024 array at 2 mm has a linear dimension of 64 mm.
- The use of NbSi compound for the thermistor. By simply varying the concentration in Nb, the thermistor can be made of semi-conducting hopping process type (high-impedance bolometers) or superconducting type (Transition Edge Superconductor TES bolometers).
- The multiplexing readout is part of the detector assembly. A new scheme with HEMT quantum-point-contacts (QPC) is being followed to multiplex high-impedance bolometer arrays. In parallel, a SQUID time-domain multiplexing scheme is also pursued for the TES option.
- Low temperature is beneficial to achieve near background limited performance of detectors. CMB physics in the millimeter domain requires from 50 to 300 mK coolers. Dilution fridges provide this range of temperatures.
- Testing the arrays requires dedicated instruments, including a Martin-Puplett interferometer in order to measure their spectral and polarization response, a calibrated black body, a prototype camera including a cryostat, some optics, filtering and baffling.

(Kuo et al. , 2006) are also designing bolometric cameras along similar lines of thought.

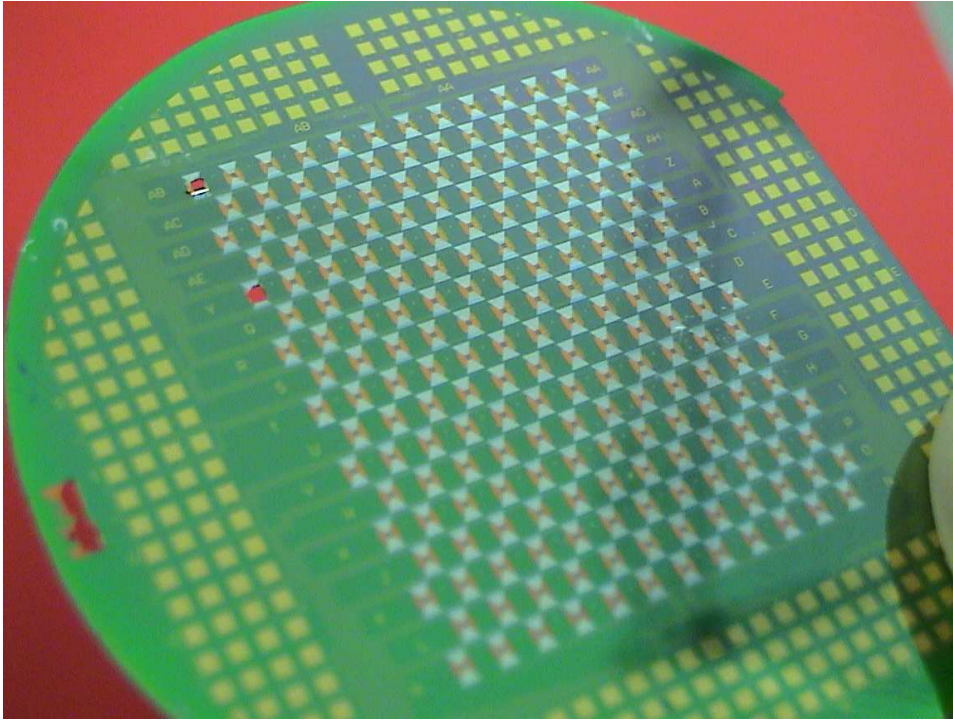

Fig. 5. 5-cm wafer detector with 204 pixels. Each pixel is made of different layers including a bow-tie pattern for the antenna, a dissipation layer, and a NbSi thermistor. Gold wires can also be seen.

An example of an early realization is shown in Fig. 5. Most of the activities in the last three years have been centered on empirically learning the pitfalls of microlithographic techniques in a slow feedback process between design, realization, and testing.

The multiplexing (Fig. 6) of high-impedance bolometers has recently been shown to work with a 1-to-12 multiplexing ratio (Yates et al. , 2006a,b). Leak currents are limited to less than 0.07 pA. Advances in the TES readout system have also been made. In particular a SiGe technology for amplification and addressing has been demonstrated at 4 K.

A small 23-pixel array is planned to be provided to the OLIMPO instrument in order to validate some of the thermistor technologies on the sky.

We pay tribute to the pioneering work by Francesco Melchiorri in the CMB polarization field and to the trust he showed us during the early Diabolo setup at MITO in 1994.

We wish to thank M. Bucher for improvements of the manuscript.



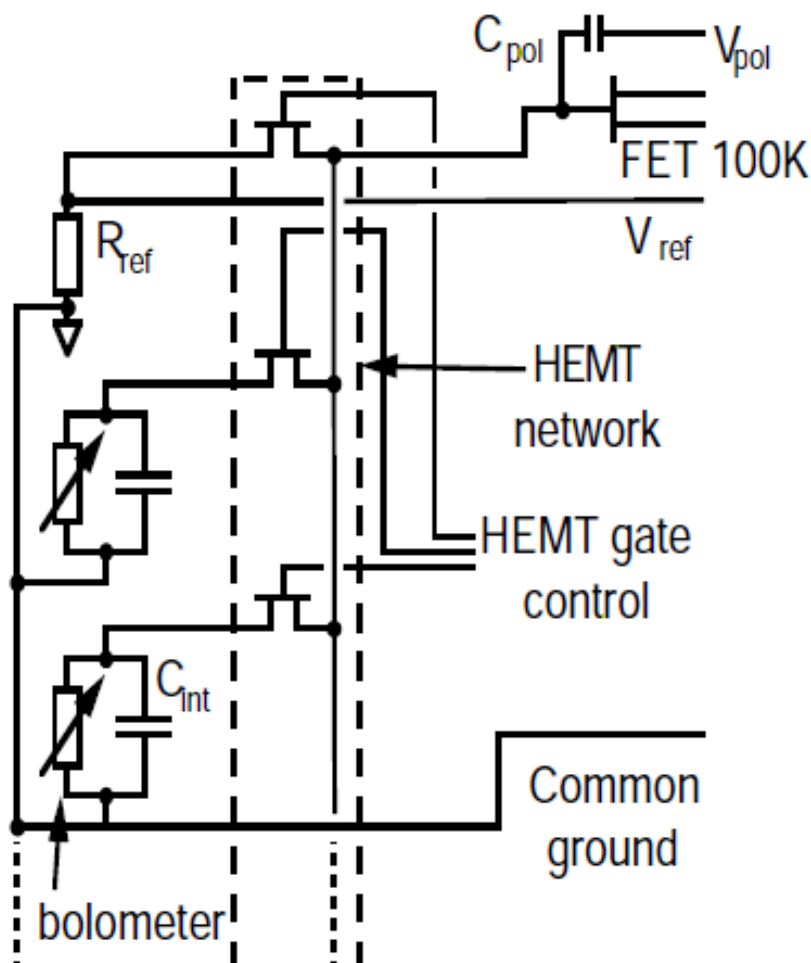

Fig. 6. Multiplexing scheme for high-impedance bolometers.

## References

- Bennett, C. L., Halpern, M., Hinshaw, G. et al., 2003, *ApJS*, 148, 1
- Bock, J. J., Day, P., Goldin, , 2002, *Proceedings Far-IR & mm detector technology Workshop*, Wolf J., Farhoomand J. and McCreight C.R. (eds.), NASA/CP-211408, [www.sofia.usra.edu/det\\_workshop](http://www.sofia.usra.edu/det_workshop)
- Bock J., Church, S., Devlin, M. et al., 2006, *astro-ph/0604101*
- Bond, J. R., & Efstathiou, G., 1984, *ApJL*, 285, L45
- Bouchet, F. R., Benoit, A., Camus, Ph. et al. 2005, *Proceed. SF2A 2005*, Eds. F. Casoli et al., *astro-ph/0510423*
- Bouchet, F. R., 2005, *Proc. 39th ESLAB Cosmic Vision Symposium*, Noordwijk, 19-21 April 2005, F. Favata, A. Gimenez. eds., ESA-SP
- Désert, F.-X., & Benoit, A, 1999, *IRAM Newsletter*, *astro-ph/9901414*,
- Kamionkowski, M., Kosowsky, A., and Stebbins, A., 1997, *Phys. Rev. Lett.*,

78, 2058  
Kuo, C. L, Bock, J. J., Chattopadhyay, G., et al. 2006, astro-ph/0606366  
The Planck Collaboration, The Scientific Programme of Planck, 2006, astro-ph/0604069  
Seljak, U. and Zeldarriaga, M., 1997, Phys. Rev. Lett., 78, 2054  
Smoot, G., Bennett, C. L, Kogut, A., et al., 1992, ApJL, 396, L1  
Yates, S. J. C., Benoit, A., Jin, Y. et al., 2006, NIMA, 559, 829, Proceed. of LTD-2005  
Yates, S. J. C. et al., 2006, in prep.